



COLLABORATING ACROSS THE IP LIFECYCLE

HOW SOFTWARE CAN HELP DEFINE AND ENFORCE YOUR PROCESSES

BOB STEMBRIDGE
IPWARE SUMMIT 2009
OCTOBER 23, 2009



THOMSON REUTERS

WHY IP MANAGEMENT IS IMPORTANT

- Greater awareness of IP and IPR value
- Backlog of patents in major 5 patent offices
 - Uncertainty for business
 - Raising the bar
- New ways of creating, managing and exploiting IP
 - Open innovation
 - Patents as options on technology
 - Increasingly liquid market-place for patents?
 - Trolling

OPEN INNOVATION

- Demand for information: internally & externally

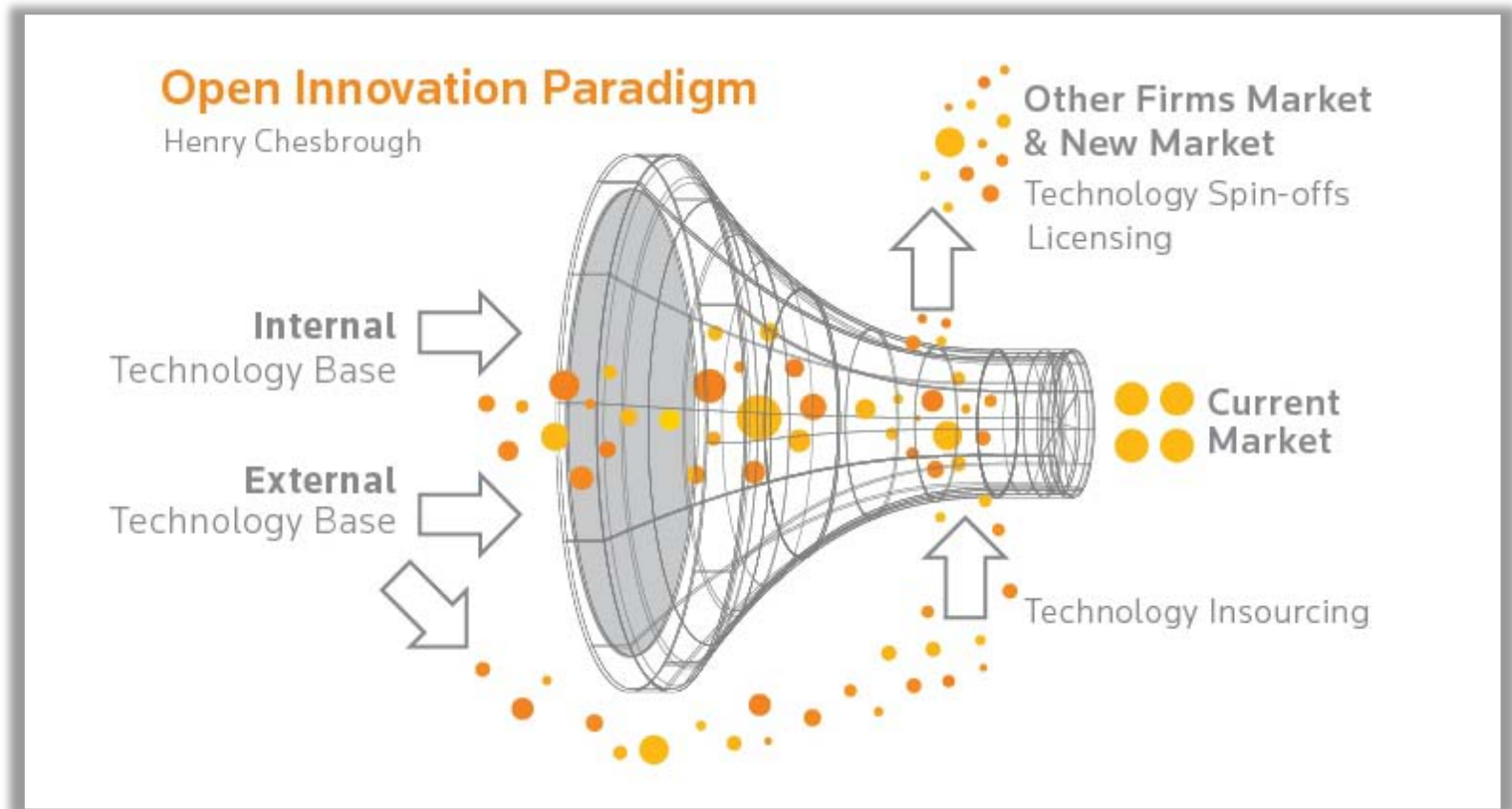

INCREASING VALUE OF INTANGIBLES

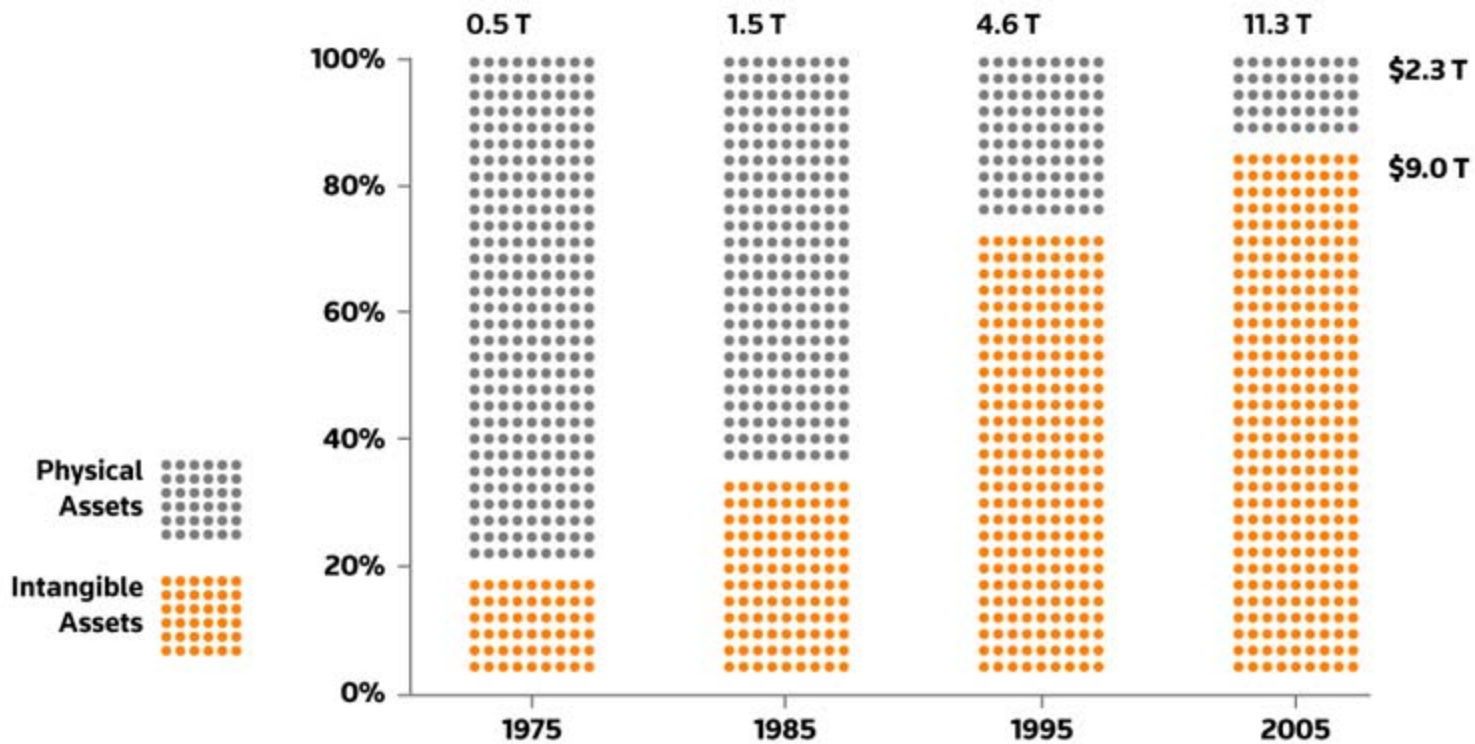

Note: S&P 500 Values are the adjusted market capitalizations from the given years
Source: Ocean Tomo, Ned Davis Research (Jan 2006); World Intellectual Property Organization "WIPO Patent Report 2007"; Standard & Poor's

WHY COLLABORATION IS IMPORTANT

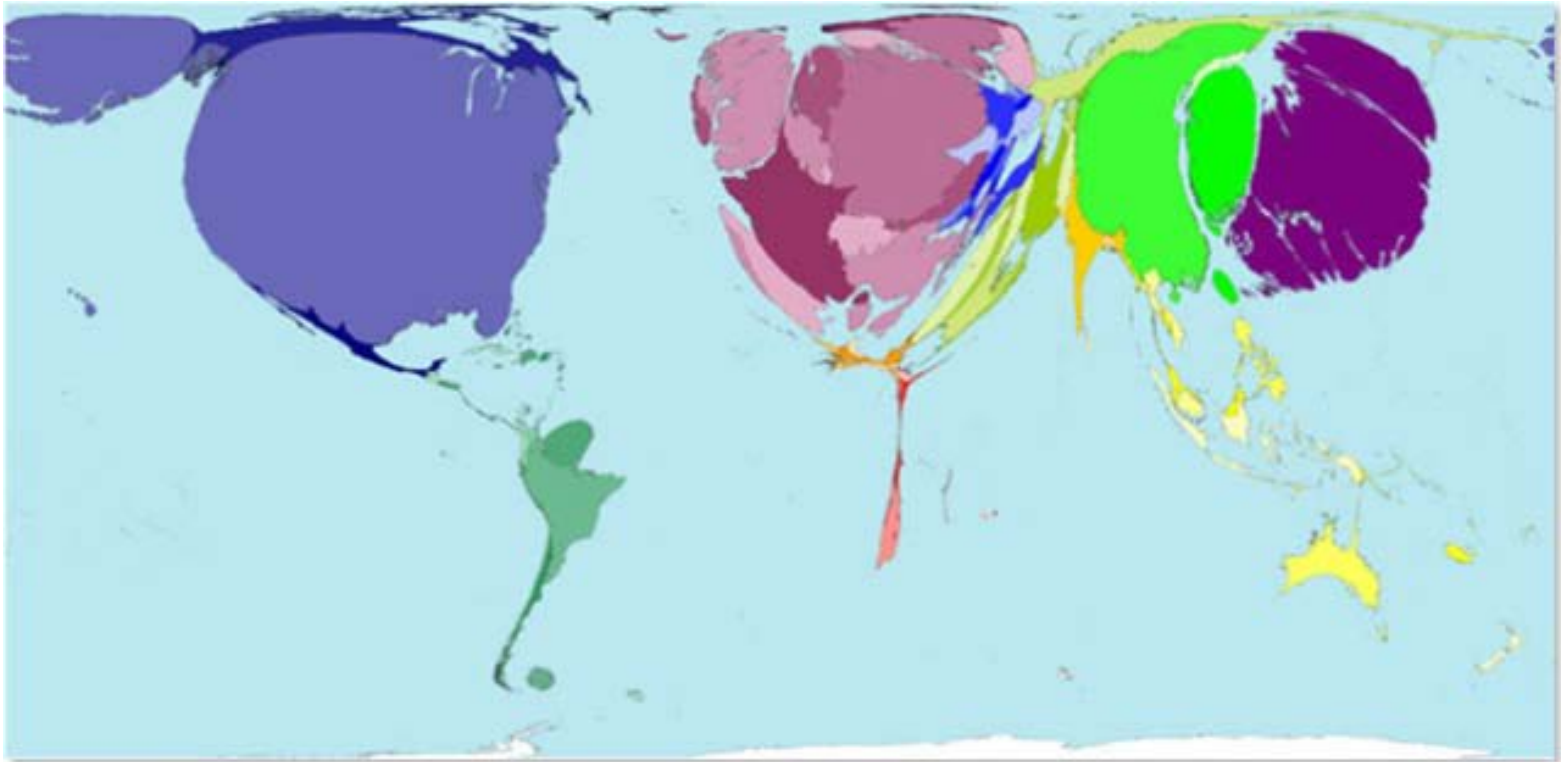

Source: <http://www.sasi.group.shef.ac.uk/worldmapper/index.html>

WHAT'S INVOLVED IN CREATING/MANAGING/EXPLOITING IP?

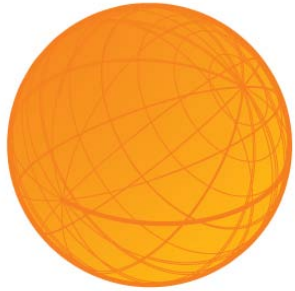

Research & Innovation

- Promote & reward innovation
- Conduct research
- New invention reviews
- Novelty searches
- Filing decisions
- Brand creation
- Acquisitions
- Technology in-licensing

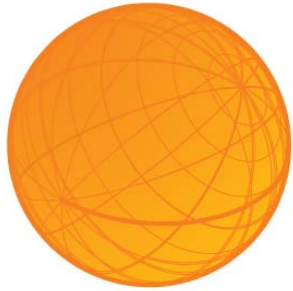

Application & Prosecution

- Select agents / counsel
- Draft applications
- Initial filing
- International filing
- Cite & track references
- Prosecute applications
- Manage daily docket

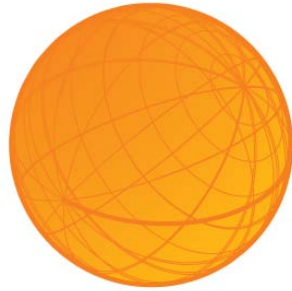

Maintenance & Monitoring

- Portfolio reviews
- Payment decisions
- Monitor / verify payments
- TM renewals
- Prove use
- Record changes of ownership / status
- Budget forecasts
- Portfolio divestitures

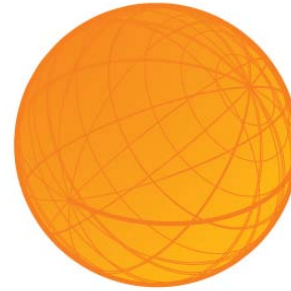

Licensing & Commercialization

- Create successful products
- Track revenue & ROI
- Technology out-licensing
- Non-disclosure agreements
- Cooperative research
- Mergers & acquisitions
- Market intelligence



Protection & Assertion

- Product marking
- Oppositions
- Cease & desist orders
- Legal opinions
- Litigation
- Identify potential infringers
- TM watch services
- Competitive intelligence

THE IP LIFECYCLE

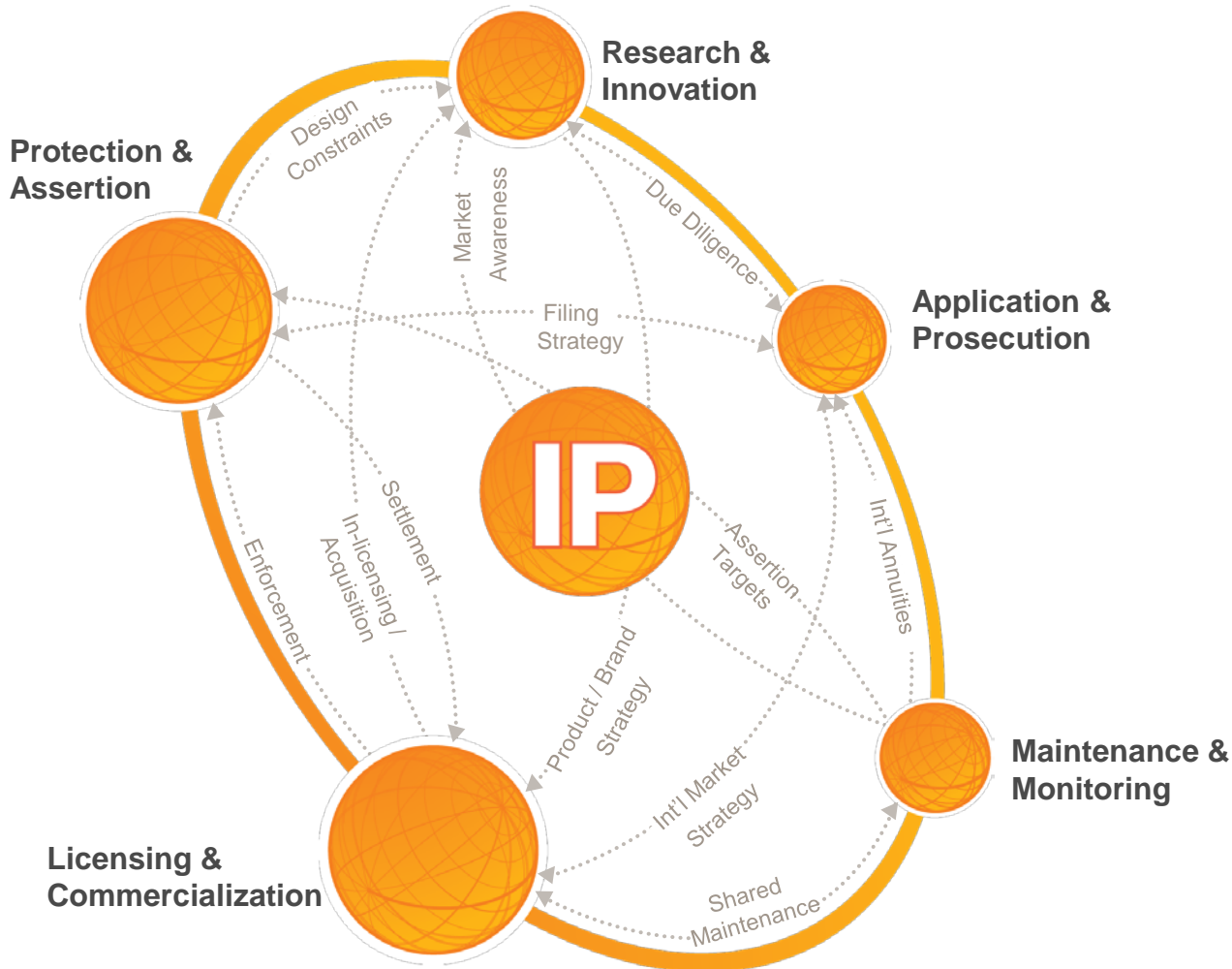

- Identify opportunities
- Make good strategic decision
- Manage the portfolio
- Optimize IP assets
- Mitigate risk

WHO'S INVOLVED?

- Business strategic planning
- Marketing/Product management
- Licensing/M&A Group
- Research & Development group
- Intellectual Property group
- Information group

THE IMPORTANCE OF STRUCTURED PROCESSES

- Silo approach hinders effective IP management
 - Risk of ill-informed maintenance decisions
 - Missed opportunities
 - Lack of visibility
- Ensure consistency of approach organisation-wide
 - Define the processes
 - Identify hand-offs, dependencies, synergies
- Deliver the right information to the right people at the right time to ensure the best decisions

CHANGE MANAGEMENT

- Processes are not enough – cultural issues need to be addressed
- Active communication is required
 - What's changing and why;
 - Celebration of successes;
 - Review of improvement opportunities
- Foster ownership of change by individuals

HOW CAN AN IP MANAGEMENT SOLUTION HELP?

- Effective creation and communication of standardised collaborative processes across the business
- Effective creation and implementation of processes through visualisation
- Controlled evolution of processes
- Automated tracking and management of portfolio administration matters (payment deadlines, rules compliance, etc.)

THE ROLE OF IP MANAGEMENT SOLUTIONS

Central collaboration point for portfolio management, bringing together all IP and business specialists on the same application

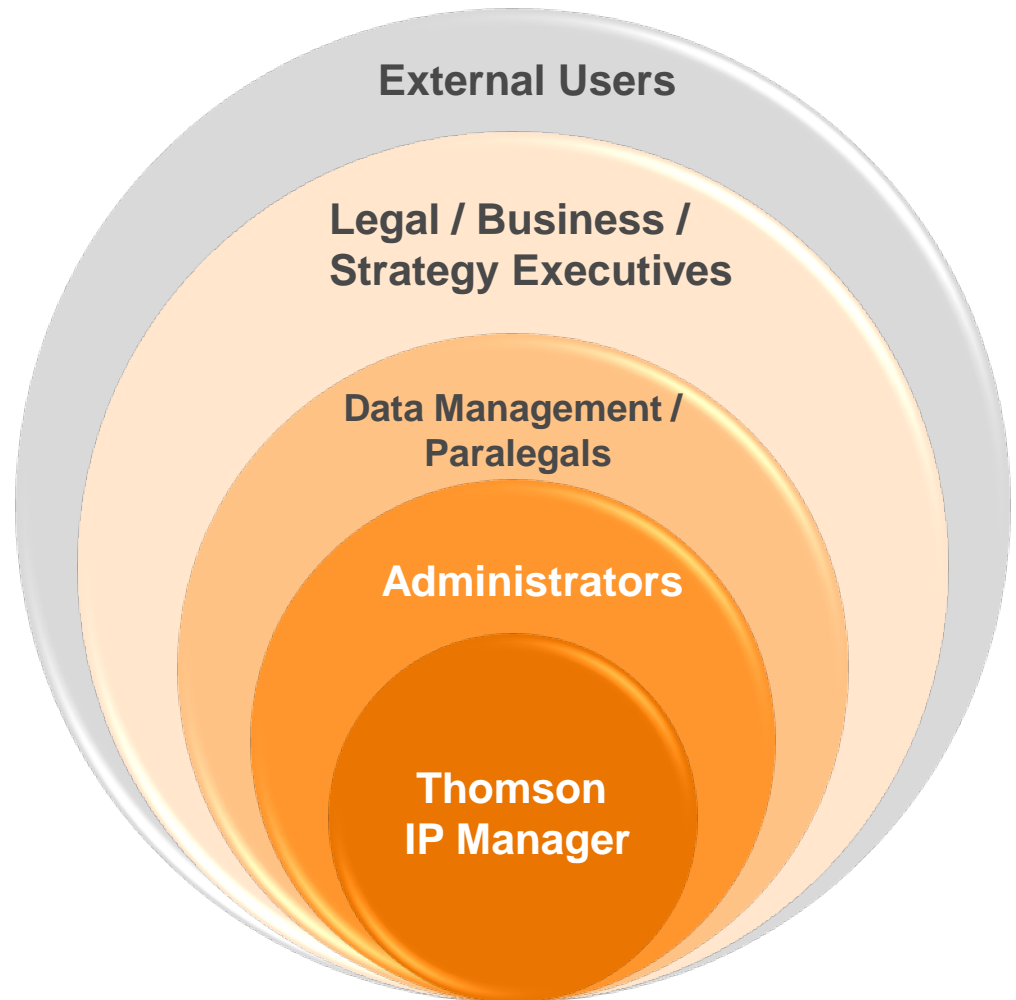

IP MANAGEMENT SOLUTIONS SUPPORT *EACH PHASE* OF THE IP LIFECYCLE

RESEARCH & INNOVATION

Inventors
Scientists
Researchers
Market Strategists

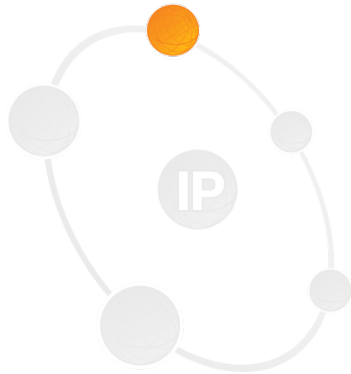

- Facilitate your invention review process
- Organize information required for due diligence
- Manage your filing decision process

IP MANAGEMENT SOLUTIONS SUPPORT *EACH PHASE* OF THE IP LIFECYCLE

APPLICATION & PROSECUTION

Inside Counsel
Outside Attorneys
Paralegals
Docketing Staff



- Calculate target filing date
- Inform filing strategy
- Ensure compliance with internal and external requirements

IP MANAGEMENT SOLUTIONS SUPPORT *EACH PHASE* OF THE IP LIFECYCLE

MONITORING & MAINTENANCE

IP Managers
Licensing Professionals
Business Executives
IP Counsel



- Ensure that you do not miss important due dates
- Perform data integrity checks for jurisdictions around the world
- Create long-term budget forecasts for annuity payments

IP MANAGEMENT SOLUTIONS SUPPORT *EACH PHASE* OF THE IP LIFECYCLE

LICENSING & COMMERCIALIZATION

IP Managers
Licensing Professionals
Business Executives
IP Counsel

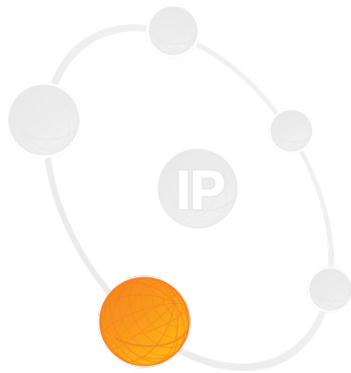

- Manage legal contracts, including licenses, research agreements, NDA's and more
- Visualize relationships between different types of matter
- Collaborate on strategic decisions within and outside your organization

IP MANAGEMENT SOLUTIONS SUPPORT *EACH PHASE* OF THE IP LIFECYCLE

PROTECTION & ASSERTION

Inside Counsel
Outside Attorneys
Paralegals
Docketing Staff

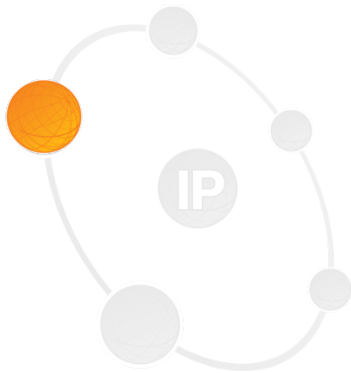

- Manage conflicts related to your IP, including oppositions and litigation
- Forecast and manage worldwide patent payments, maintenance fees, and trademark renewals
- Ensure consistency and integrity of data with embedded safeguards

THOMSON IP MANAGER CORE TECHNOLOGIES SUMMARY

- Core components comprise:
 - Electronic Portfolio
 - IP Rules
 - Payment Management
 - Clean Data technology
 - ViewPoint self-service tools
 - Portfolio Connectors
 - **Enterprise Connectors**
 - **Process Architect**

ENTERPRISE CONNECTORS: LDAP & AD INTEGRATION

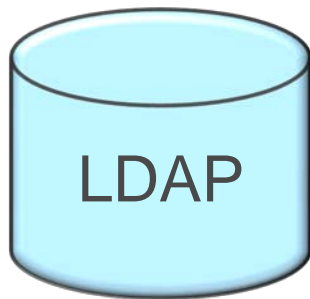

- Synchronize data from your central personnel database
- Maintain current status, location and contact information for inventors
- Identify resource risks (inventors retiring, moving)

The screenshot shows a web browser window titled "Party Data Modification - Windows Internet Explorer". The URL is <http://ipmua1.masterdatacenter.com/ipmanager/PartyDataModificationScreen.aspx?ElementID=10000&ElementType=PARTYDETAILS>. The page displays a "Party Detail" form with the following fields:

First Name	Thomas	Middle Initial	A	Last Name	Edison
Party	Edison, Thomas	Email	test@thomsonreuters.com		
Address 1	123 Main Street		Address 2		
Registration #		Citizenship	United States		
Line 2		Line 3			
Line 4		Line 5			
Line 6	Edison, NJ 08817		Resident Country	United States	
Phone	908-555-1234		Fax		
Telex		Zipcode	08817		
Comments					

At the bottom of the form, there is a summary section:

UPDATEUSER	UPDATEDATE	CREATEUSER	CREATEDATE
DBAdmin01	10-Nov-08 2:16:48 PM	ipmanager	17-Mar-08 2:59:37 PM

Below the form, there are sections for "Related Parties", "Custom Text", "Custom Number", "Custom Addresses", "Custom Dates", and "Custom Codes".

PROCESS ARCHITECT

Process Designer

Save Cancel Reset Delete Duplicate

Process is successfully saved

Name: TM Foreign Filing Review Description: Review Trademark application for secondary filing decision

IPType: TrademarkMasters Priority: 0 Purge Comments on Completion:

Owner: Demo Resource Admin Collaboration Level: Matter Active:

Initial Task: Provide Filing Instructions

Invoke Permissions: Available Content Groups: Default Admin Content Group, Global Change, Extract, Demo Docket Specialist, Demo Attorney, Demo Inventor, Demo Business Executive, Demo Outside Counsel

Selected Content Groups: [Empty]

Define matter, action or portfolio level processes

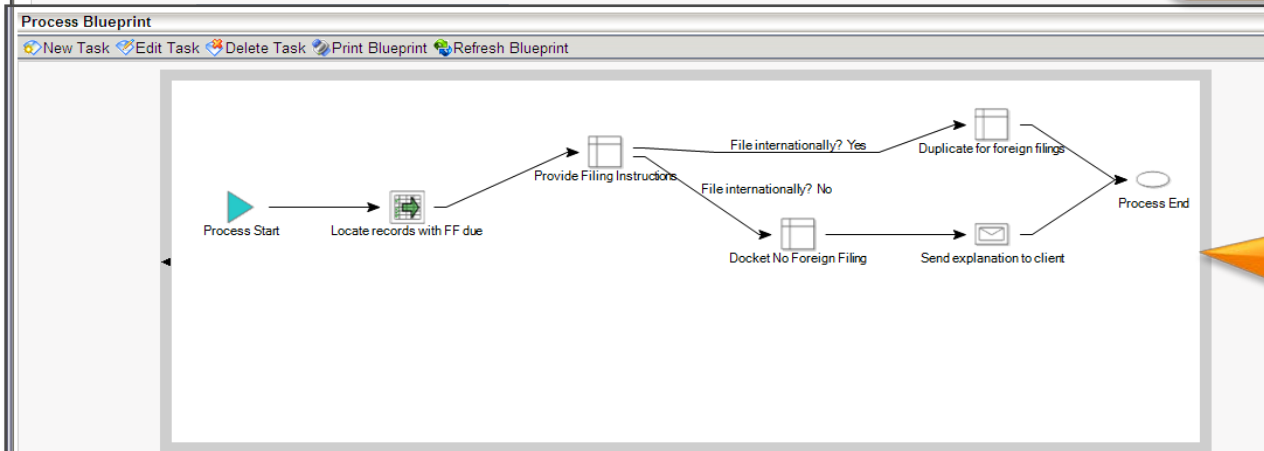

Design processes visually

Scheduled Initiation

Schedule: Start 23-Jul-09 10:00 AM

Recurrence Pattern: Daily Weekly Monthly Recur every 1 day(s) Every weekday

Range of Recurrence: No end date End after: 1 occurrences End by: [Dropdown]

Create scheduled self-initiating processes

PROCESS ARCHITECT: COLLABORATION PORTAL

The screenshot displays the 'Task View Criteria Builder' window. At the top, there are buttons for 'Run Query', 'Validate', 'New', 'SaveAs', 'Reset', and 'Edit'. Below this is the 'Selection Criteria' section, which includes a table with columns for 'Field Name', 'Operator', 'Value', and 'Conjunction'. The 'Field Name' dropdown is set to 'MarkName' and the 'Operator' is set to 'Equal'. A callout bubble points to this section with the text: 'Filter task list using familiar query interface'.

Below the criteria builder is a 'Task View Query Results : All records' window. It features a toolbar with buttons for 'Submit', 'Delegate', 'Return', 'Remove', and 'New Record'. A second callout bubble points to the 'Submit' button with the text: 'Submit records individually or in groups'.

The main results area contains a table with the following data:

	MarkName	Docket Number	Country	Current Division	Current Owner	Current Ap
<input type="checkbox"/>	AIRFRESH	200001.71497	United States	Regular	National	Real Technologies 14-Jan-08
<input type="checkbox"/>	QUIK LOG	200007.71526	United States	Regular	National	Arthur C. Woodmere Commercial Electronics Innovation Holdings 24-Dec-07

At the bottom of the interface, there is a 'Total Record Count: 2 of 2' and a 'View selected record in' dropdown menu set to 'Trademark', with a 'Record Management Form' button next to it. The Thomson Reuters logo is visible in the bottom left corner.

SAMPLE BLUEPRINT: INVENTION DISCLOSURE AND REVIEW

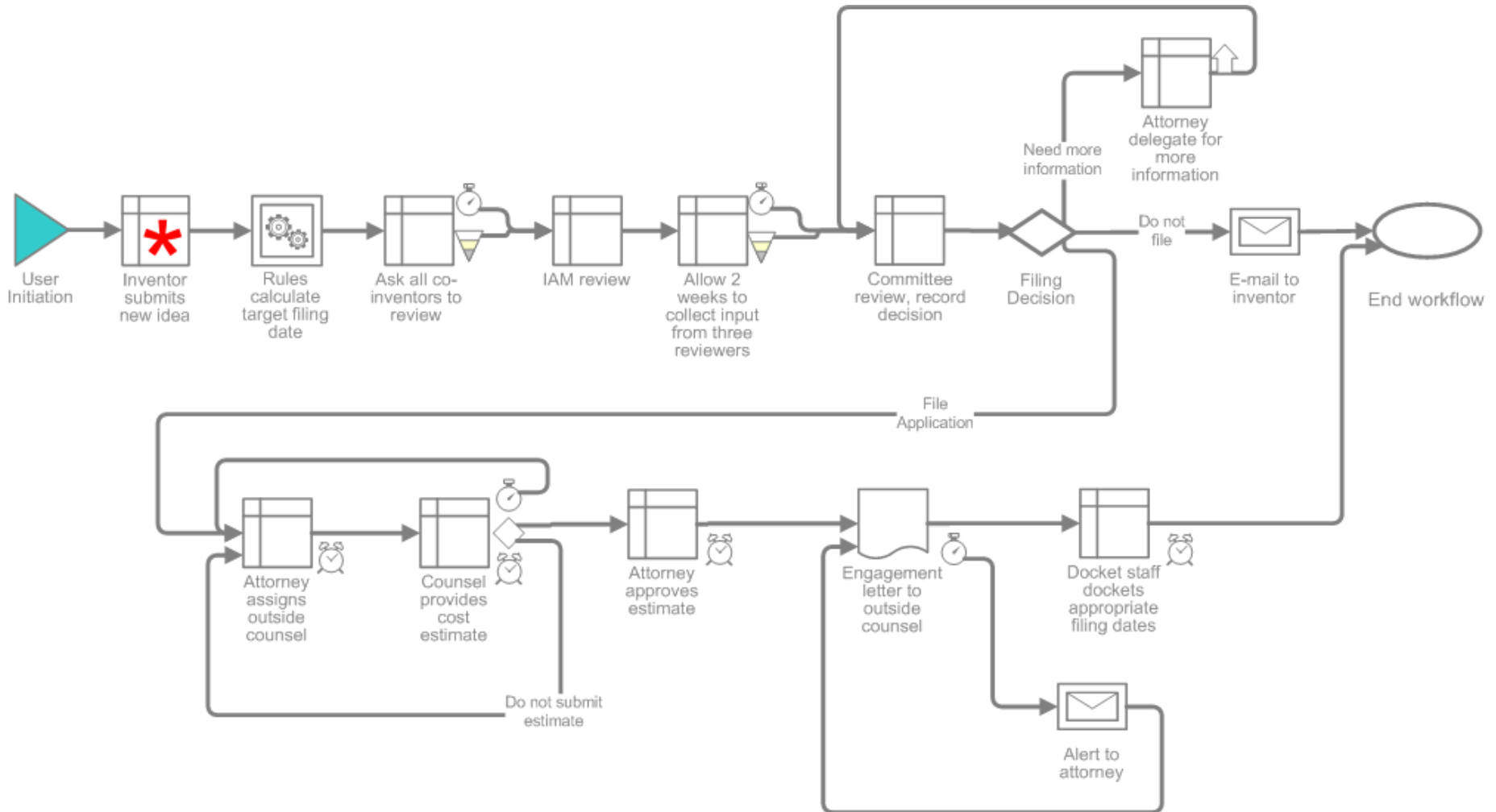

SUMMARY

- The IP Portfolio is one of the organization's most valuable assets
- Effective creation, management and exploitation of the IP pipeline is a critical component of an organization's business strategy
- Structured, collaborative processes with stakeholder buy-in help ensure successful exploitation of IP
- An effectively implemented IP management solution is crucial to ensure successfully managed structured collaborative processes with stakeholder buy-in across the organization

ACKNOWLEDGEMENTS

Grateful thanks are due to my colleagues from Thomson IP Management Services who helped develop this presentation:

- Adam Kenney, Product Manager
- Phillip Henderson, VP, Customer Operations
- Sherry Kappel, Marketing Manager

THANK YOU!



THOMSON REUTERS